

# Continuous performance

## Ingersoll Rand Rotary Compressor 5.5 – 11 kW

50 Hz Performance Data			
Model	Nominal Power kW (hp)	Working Pressure barg (psig)	Capacity (FAD) m <sup>3</sup> /min (cfm)
R5IU - A7	5.5 (7.5)	7 (102)	0.83 (29.3)
R5IU - A8	5.5 (7.5)	8 (116)	0.78 (27.5)
R5IU - A10	5.5 (7.5)	10 (145)	0.70 (24.7)
R7IU - A7	7.5 (10)	7 (102)	1.10 (38.8)
R7IU - A8	7.5 (10)	8 (116)	1.03 (36.3)
R7IU - A10	7.5 (10)	10 (145)	0.91 (32.1)
R11IU - A7	11 (15)	7 (102)	1.63 (57.5)
R11IU - A8	11 (15)	8 (116)	1.52 (53.6)
R11IU - A10	11 (15)	10 (145)	1.35 (47.6)

Dimensions & Weights				
5.5 – 11 kW / 7.5 – 15 hp	Length mm (in)	Width mm (in)	Height mm (in)	Weight kg (lb)
Baseplate	826 (32.52")	759 (29.88")	782 (30.79")	280 (617)
272 Liter / 71 gal	1343 (52.87")	759 (29.88")	1433 (56.42")	450 (992)

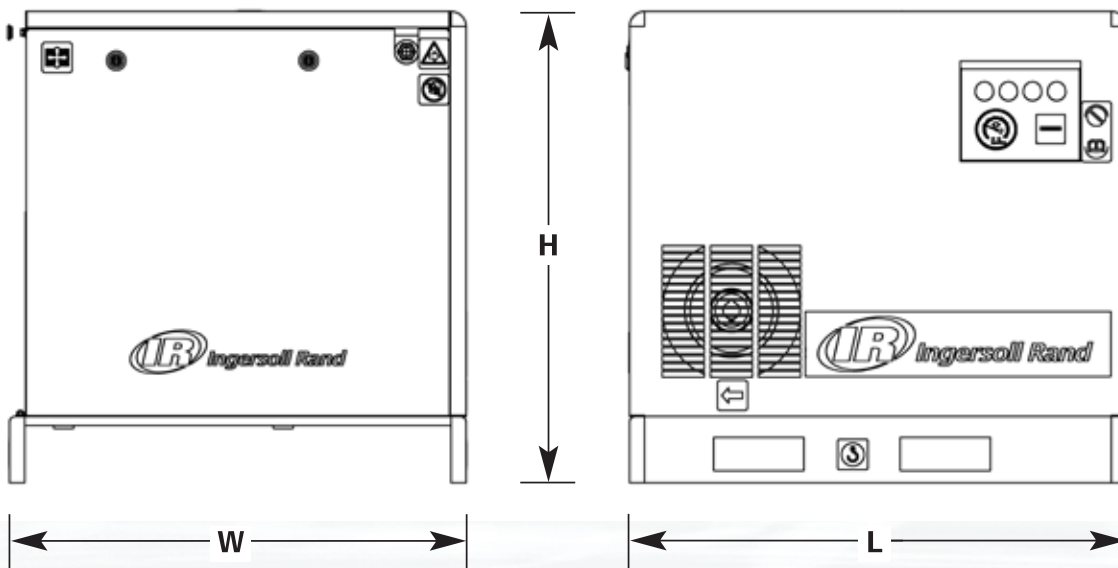

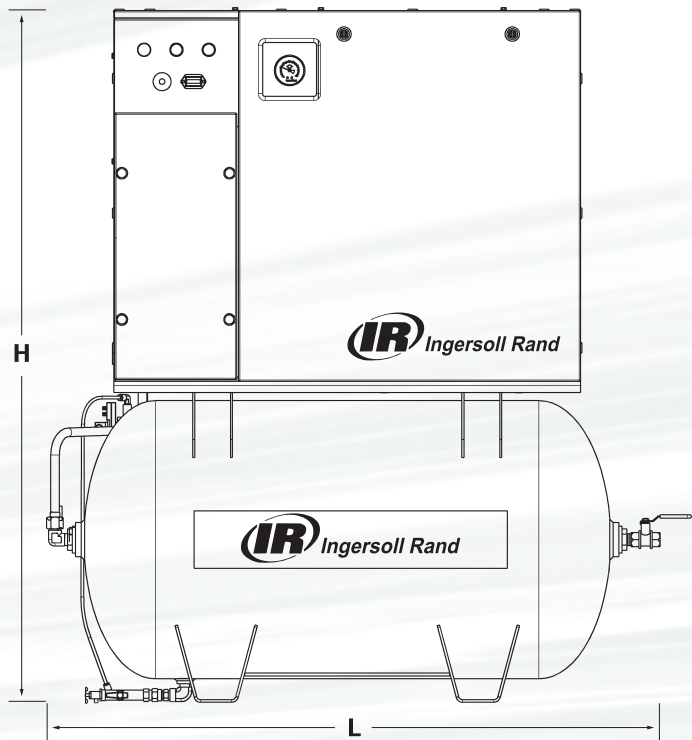
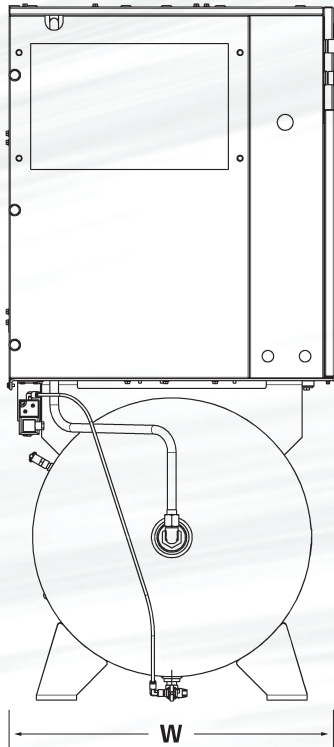

### Industry Leading Performance

50 Hertz Total Air System Specifications									60 Hertz Total Air System Specifications						
Package	Model No. Compressor	kW	Discharge pressure Compressor Package		Capacity*		dBA**	Package	Model No. Compressor	hp	Discharge pressure Compressor Package		Capacity*		dBA**
			barg	barg	m <sup>3</sup> /min	cfm					psig	psig	cfm	m <sup>3</sup> /min	
UP5-4TAS-8	UP5-4-8	4	8	7.3	0.55	19.5	65	UP6-5TAS-125	UP6-5-125	5	125	115	18.5	0.52	65
UP5-4TAS-10	UP5-4-10	4	10	9.3	0.45	16	65	UP6-5TAS-150	UP6-5-150	5	150	140	16.0	0.45	65
UP5-5TAS-8	UP5-5-8	5.5	8	7.3	0.82	29	65	UP6-7TAS-125	UP6-7-125	7.5	125	115	28.0	0.79	65
UP5-5TAS-10	UP5-5-10	5.5	10	9.3	0.74	26	65	UP6-7TAS-150	UP6-7-150	7.5	150	140	25.0	0.25	65
UP5-5TAS-14	UP5-5-14	5.5	14.5	13.8	0.51	18	65	UP6-7TAS-210	UP6-7-210	7.5	210	200	17.5	0.50	65
UP5-7TAS-8	UP5-7-8	7.5	8	7.3	1.08	38	68	UP6-10TAS-125	UP6-10-125	10	125	115	38.0	1.08	68
UP5-7TAS-10	UP5-7-10	7.5	10	9.3	0.96	34	68	UP6-10TAS-150	UP6-10-150	10	150	140	34.0	0.96	68
UP5-7TAS-14	UP5-7-14	7.5	14.5	13.8	0.68	24	68	UP6-10TAS-210	UP6-10-210	10	210	200	24.0	0.68	68
UP5-11cTAS-8	UP5-11c-8	11	8	7.3	1.60	56.5	69	UP6-15cTAS-125	UP6-15c-125	15	125	115	55.0	1.55	69
UP5-11cTAS-10	UP5-11c-10	11	10	9.3	1.42	50	69	UP6-15cTAS-150	UP6-15c-150	15	150	140	50.0	1.42	69
UP5-11cTAS-14	UP5-11c-14	11	14.5	13.8	1.08	38	69	UP6-15cTAS-210	UP6-15c-210	15	210	200	38.0	1.08	69

Dimensions & Weight						Compressor Package				Compressor (Without Air Treatment System)	
50 & 60 Hertz baseplate and receiver mounted units						Package				Compressor (Without Air Treatment System)	
	Length		Width		Height		Weight		Weight		
	inch	mm	inch	mm	inch	mm	pounds	kg	pounds	kg	
Base mount	41	1042	28.9	734	36	914	725	330	650	295	
272 Litre Receiver Tank	51.6	1311	28.9	734	60.7	1541	1003	455	928	420	
500 Litre Receiver Tank	81	2059	28.9	734	60.7	1541	1080	490	1005	455	

\* Performance in accordance with ISO 1217 1996 annex C

\*\* Measured in accordance with CAGI-pneurop test code PN8NTC2.3